

Overcurrent Time Protections

AT 12 DX, AT 21 DX, AT 31 DX

Application:

The protection relays AT 12 DX (single-phase), AT 21 DX (two-phase), AT 31 DX (three-phase) are used as overcurrent relays of electrical appliances at overload and short-circuit. They are time-delayed independent protections. It means the protections operate if the current exceeds a preset value and a preset time is elapsed. The protections are direct replacement the AT 12 X1, AT 21 X1 and AT 31 X1 types with identical dimensions and connection of terminals. The protections are equipped with the signalling contact loss of auxiliary voltage.

Description:

AT 12 DX, AT 21 DX a AT 31 DX are steady-state protections. The measuring elements each of phases have independent adjustment and their performance is delayed 60-75 ms, so that the protection doesn't inclined to inrush current of electrical equipment.

The relay A at the measuring element operates if any current exceeds a value preset on the control panel. The signalling of the relay operation is realized by a memory circuit and the red LED. The LED is shut down by RESET push-buttons situated on the front panel and on the casing as well.

The time element is started from the relay A (if the terminals 5-6 at AT 12 DX or terminals 15-16 at AT 21 DX and AT 31 DX are connected). If the relay A returns to quiescent state in time shorter than a preset time (a failure state drops out), the output relays E and Ep don't operate and only the measuring element action (the respective phase) is signallized on the front panel. If the relay A continues in operation (a failure persists) a preset time delay elapses and the output relays E and Ep operate.

The output relay E has non-memory contacts e1 and e2, which return to quiescent state with the returning a measure element. The output memory relay Ep has contacts ep1 and ep2, that return to quiescent state by the RESET push-button. The contact ep2 controls the signalling LED I>t, this signalling doesn't change in case of a loss of auxiliary voltage. It indicates a previous protection activity after an auxiliary voltage restoration.

The protections need auxiliary voltage for their operation. The protections are produced in two designs (auxiliary feeding ranges): 18 - 60 V AC, DC and 40 - 265 V AC, DC. The relay Z for loss of auxiliary voltage has break contact between terminals 3 and 4. An auxiliary voltage presence is indicated by green LED.

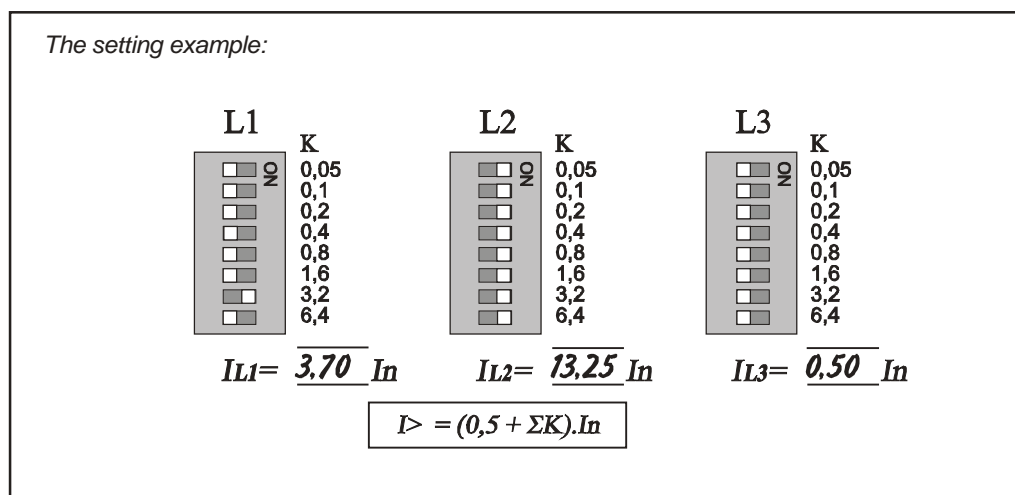

Fig. 1 The view of the front panel - measure elements setting

The L1 phase - setting at $I_{>} = 3,70 I_n$

The L2 phase - setting at $I_{>} = 13,25 I_n$

The L3 phase - setting at $I_{>} = 0,50 I_n$

Testing:

The protection testing is possible with removed cover and coincident pressing TEST and RESET push-buttons.

The course of the testing: the relay A starts in operation and after the time delay elapse the output relays E and Ep operate.

Attention: Don't test during an operation!

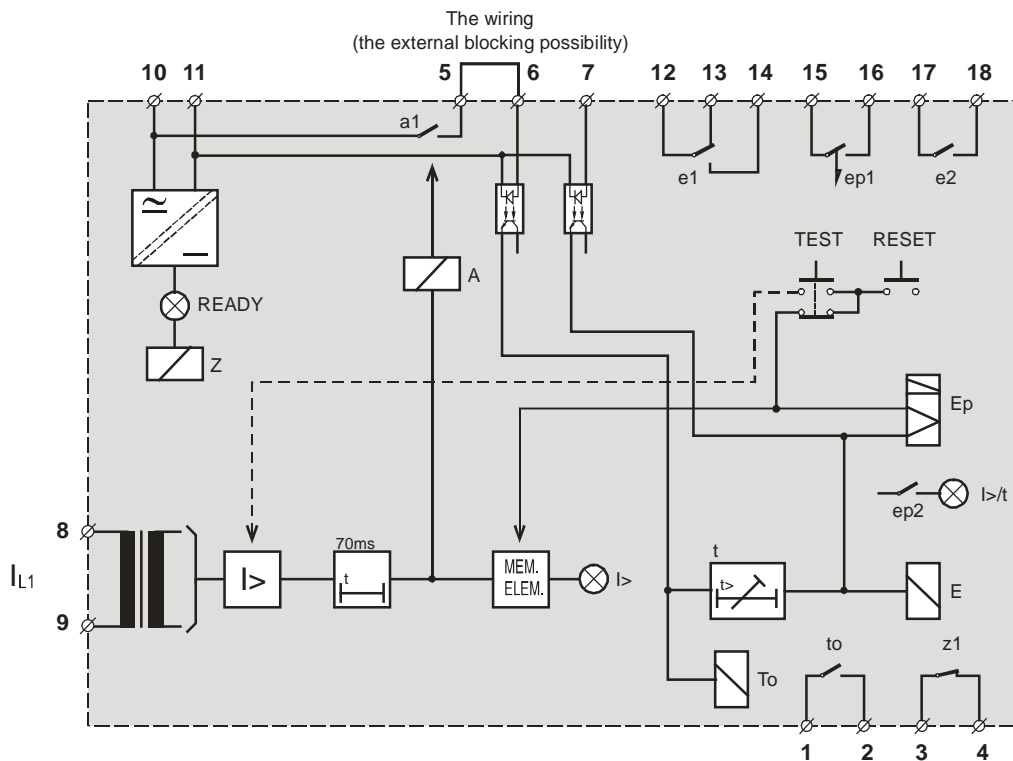

Fig. 2 The block diagram of the protection AT 12 DX

Technical data:

Rated current I_n 1 or 5 A
 Nominal frequency f_n 50 or 60 Hz
 Current circuit consumption < 0,5 VA for $I_n = 5$ A; < 0,05 VA for $I_n = 1$ A

Auxiliary voltage E

Voltage ranges 18 - 60 V DC, AC or 40 - 265 V DC, AC
 Auxiliary circuit consumption < 7 W
 Overshoot time to current reduced:
 - 18 - 60 V DC, AC design $t_p < 0,2$ s at 48 V DC, AC; $t_p < 0,3$ s at 60 V DC, AC
 - 40 - 265 V DC, AC design $t_p < 0,2$ s at 110 V DC, AC; $t_p < 0,9$ s at 220 V DC, AC
 Ground terminal on the casing
 Fuse nominal value 2 A

Measuring elements

Adjustability	from 0,5 to 13,25 I_n by 0,05 I_n
Accuracy	$\pm 5\%$ of the preset value
Resetting ratio	0,93 - 0,96
Operation delay of the measuring element (a1)	60 - 75 ms
Return time of the measuring element (a1)	30 - 50 ms
Overload capacity	
- thermal	4 I_n / permanently; 10 I_n / 8 s; 70 I_n / 1 s
- dynamic (for half cycle)	200 I_n

Time element

Total time delay $t >$	$t_0 + \Sigma K$
Basic time delay t_0	75 ms $\pm 10\%$
Time setting range ΣK	from 0,05 to 12,8 s by 0,05 s or from 0,1 to 25,6 s by 0,1 s
Time accuracy	$\pm 1\%$ from value $t >$

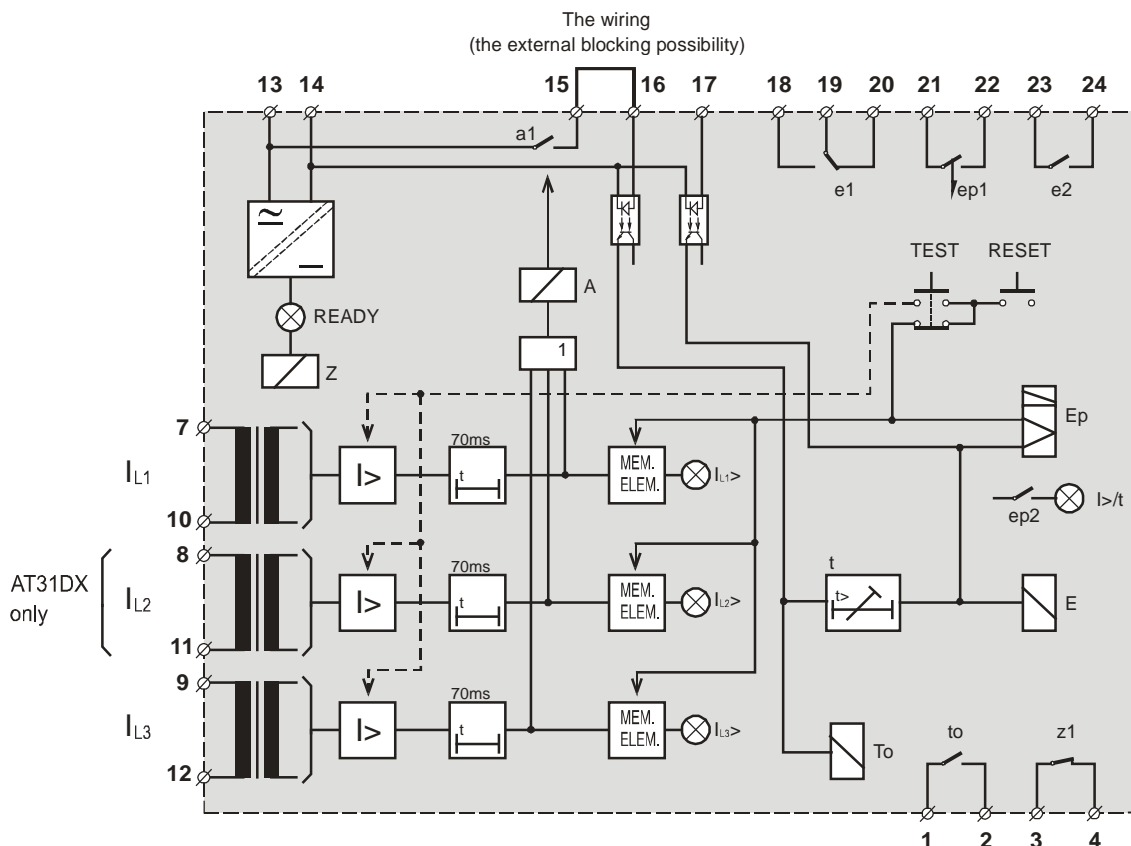

Fig. 3 The block diagram of the protections AT 21 DX and AT 31 DX

Contacts

Sustained rating	4 A
Switching capacity and rating for time 0,5 s	20 A
Shock loading for time 30 ms	100 A
Switching capacity for 110 V AC	2000 VA
Maximum switching voltage	250 V DC, AC
Breaking capacity for R/L = 40 ms	1,5 A at U = 50 V DC 0,3 A at U = 110 V DC 0,1 A at U = 220 V DC

Material

- relays A, To, Z	AgCd0
- relays E, Ep	AgNi 90/10

Binary inputs

Number	2
Input resistance	Rvst = 18 kΩ for E = 18 - 60 V DC, AC Rvst = 36 kΩ for E = 40 - 265 V DC, AC
Input voltage	18 - 60 V DC, AC for E = 18 - 60 V DC, AC 40 - 265 V DC, AC for E = 40 - 265 V DC, AC
Threshold voltage	17,5 V for E = 18 - 60 V DC, AC 38 V for E = 40 - 265 V DC, AC
Maximum input current	< 8 mA
Activating time	< 1 ms

Signalling LEDs

READY	green	- auxiliary voltage presence
IL1>, IL2>, IL3>	red	- measuring elements operation
I>/t	red	- time delay elapse and output relays E and E operation

Working environment

Temperature range	from -25 to +55 °C
Working position	arbitrary
Operation type	continual

Insulating tests

Insulation strength	2 kV, 50 Hz, 1 min	IEC 60255-5
Pulse voltage test	5 kV; 1,2/50 μs	IEC 60255-5

Electromagnetic compatibility (EMC)

Electrostatic discharge	6/8 kV (10 cycles)	IEC 1000-4-2
Interference of radio frequency	10 V/m	IEC 1000-4-3
Impulse group	2/4 kV / 5 kHz	IEC 1000-4-4
Induced HF field propagate by line	from 150 kHz to 80 MHz / 10 V	IEC 1000-4-6
Magnetic field disturbance	100 A/m	IEC 1000-4-8

Mechanical performance

IP code	IP 20
Terminals	one conductor from 1,5 to 6 mm ² two conductors from 1 to 2,5 mm ²
Weight (AT12DX / AT21DX / AT31DX)	2,5 / 3 / 3,5 kg

Information required for ordering:

In - rated current
E - auxiliary voltage range
t - time delay range
fn - nominal frequency

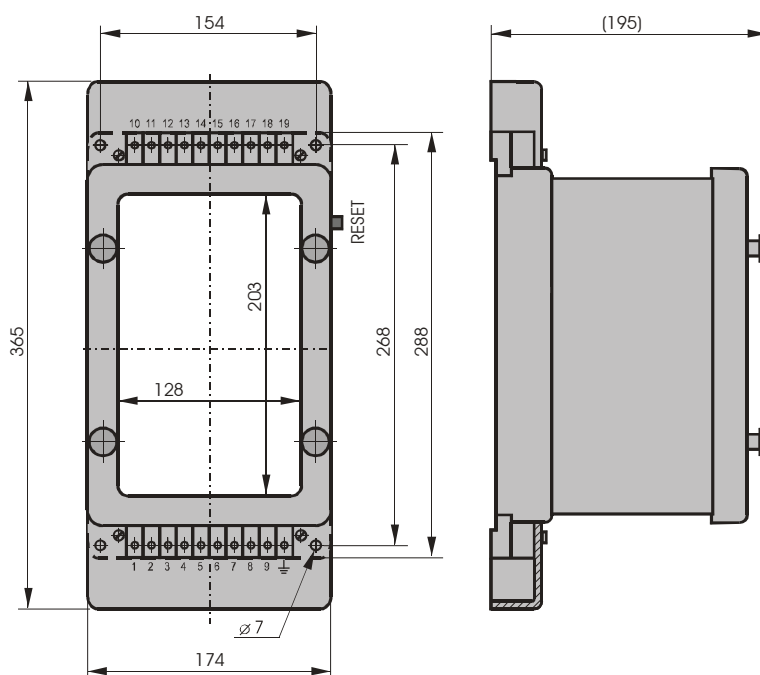
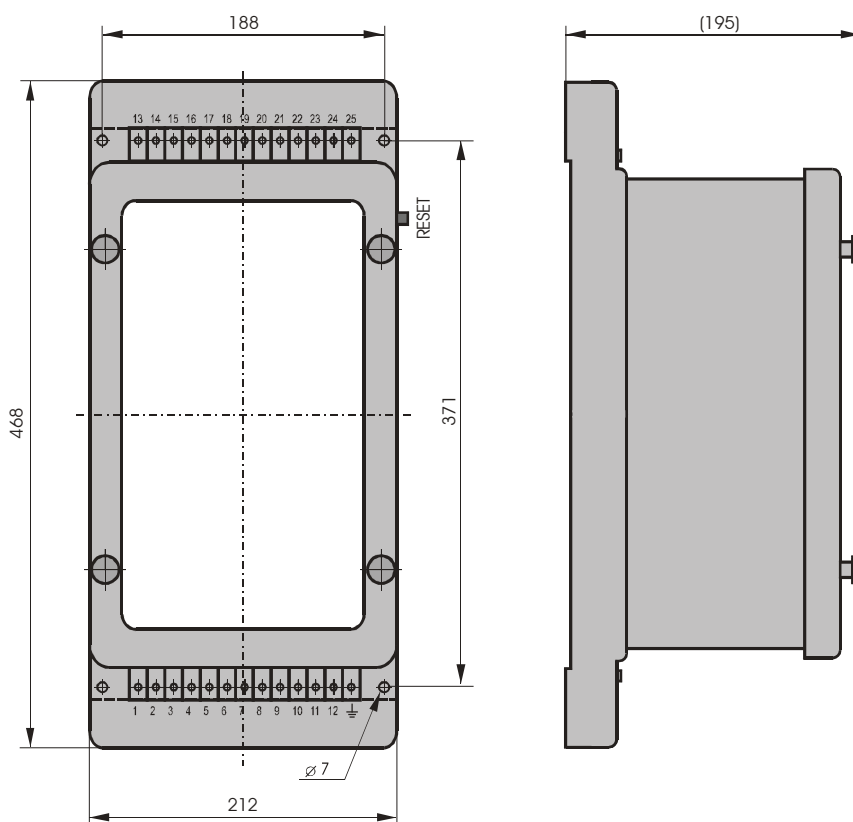

Fig. 4 The terminals position and dimensions protection AT 12 DX



For non-tolerated dimensions is valid ČSN ISO 2768-2

Fig. 5 The terminals position and dimensions protections AT 21 DX and AT 31 DX