

Voltage Protection

V 32 DX0

Application:

Protection V 32 DX0 is an accuracy three phase overvoltage or undervoltage protection relay for voltage increase over- or voltage decrease a under- preset value. The protection is direct replacement the V 32 type with identical dimensions. Connection of terminals is different.

Description:

V 32 DX0 is steady-state protection. Each of phases have independent setting (L1, L2, L3) and signalling (UL1, UL2, UL3) and they can work in overvoltage or undervoltage regime. This regime is adjusted by switch U> - U< (see Fig. 1). A preset voltage values (at DIL switches) apply for both regimes U< or U>.

An output relay of each phase has one break contact (Z) or make contact (R) (according to protection model). This relay operates after exceeding a preset value at U> regime or after drop under preset value at U< regime.

The signalling of operation each of phases is performed by memory circuit with LEDs (UL1, UL2, UL3). The LEDs are shut down by RESET push-buttons situated on the front panel and at the casing as well.

The protection needs auxiliary voltage for its operation. It is produced in two designs (auxiliary feeding ranges); 18 - 60 V AC, DC and 40 - 265 V AC, DC. An auxiliary voltage presence is indicated by the green LED. V 32 DX0 is equipped with the signalling contact loss of auxiliary voltage. The relay Z for loss of auxiliary voltage is excited during a correct feeding. The state of contacts relay Z at Fig. 2 is valid for an auxiliary voltage absence.

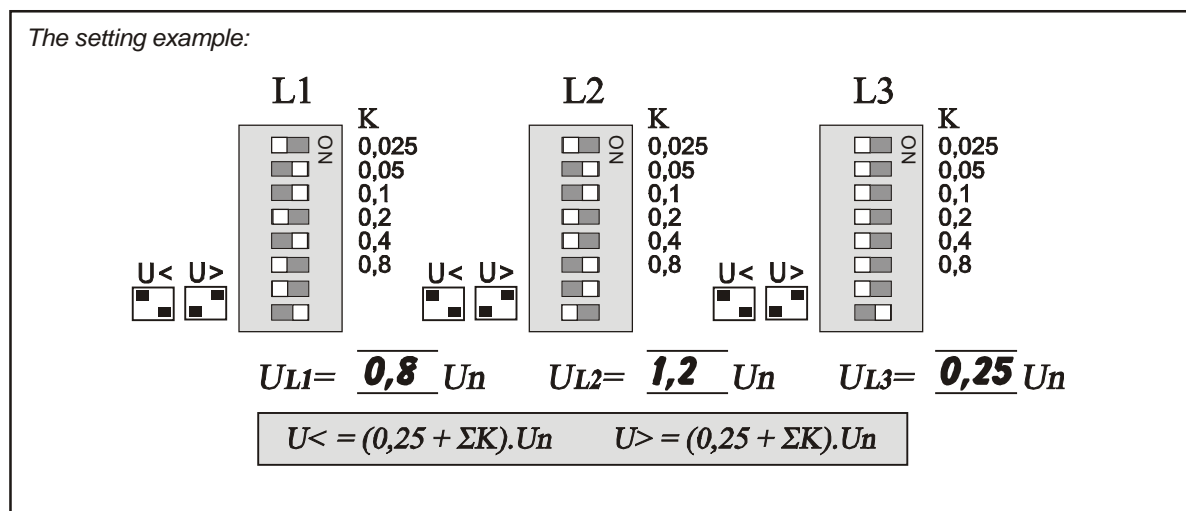

Fig. 1 The view of the control part a front panel a protection V 32 DX0

The L1 phase - setting at U< = 0,8 Un	$\Sigma K = 0,8 - 0,25 = 0,55$	= $\boxed{0,4} + \boxed{0,1} + \boxed{0,05}$
The L2 phase - setting at U> = 1,2 Un	$\Sigma K = 1,2 - 0,25 = 0,95$	= $\boxed{0,8} + \boxed{0,1} + \boxed{0,05}$
The L3 phase - setting at U< = 0,25 Un	$\Sigma K = 0,25 - 0,25 = 0$	

Testing:

The protection testing is possible with removed cover. Testing is available in two regimes:

1. The testing of impulse elements and signalling - TEST push-button

This testing regime is possible also during operation. With pressing TEST push-button is simulated operation of impulse elements and signalling LEDs (UL1, UL2, UL3). Output relays are blocked.

2. The testing of signalling and output relays - TEST + RESET push-buttons

The coincident pressing TEST and RESET push-buttons started testing regime „TEST OUT“, which is simulated the protection operation in all three phases including output relays RL1, RL2, RL3.

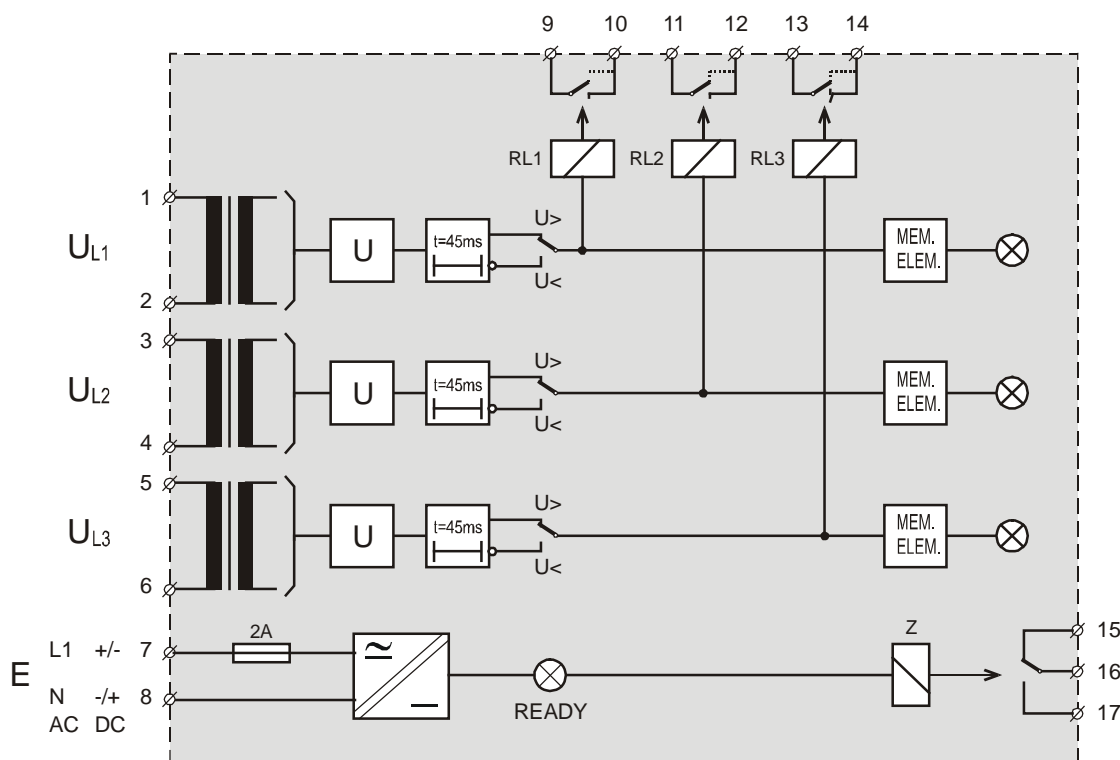

Fig. 2 The block diagram of the protection V 32 DX0

Technical data:

Nominal voltage U_n	100 V / $\sqrt{3}$ or 100 V; 230 V or 400 V
Nominal frequency f_n	50 or 60 Hz
Auxiliary voltage	18 - 60 V DC, AC or 40 - 265 V DC, AC
Serviceability	to 1s from connection the auxiliary voltage
Voltage circuit consumption	cca 0,5 VA at U_n
Auxiliary circuit consumption	< 5 W
Adjustability	from 0,25 to 1,825 U_n by 0,025 U_n ; from 0,2 to 1,46 U_n by 0,02 U_n
Permanent overload	2 U_n ; 1,6 U_n
Accuracy	± 3 % of the preset value
Resetting ratio of regime U> (U<)	0,98 (1,02)
Signalling	independently by each phases UL1, UL2, UL3
Rise (return) time	45 - 50 ms ± 5 ms

Contacts

Number	3x make or 3x break (relays RL1, RL2, RL3) 1x break-make (relay Z)
Switching current	15 A; 4 s
Sustained rating	4 A
Breaking capacity	cca 0,12 A at 250 V (from 35 to 330 W according voltage) L/R ≤ 10 ms

Insulating tests

Insulation strength	2 kV, 50 Hz, 1 min	IEC 60255-5
Pulse voltage test	5 kV; 1,2/50 μs	IEC 60255-5

Electromagnetic compatibility (EMC)

Interference of radio frequency	10 V/m	ČSN EN 61000-4-3
Impulse group	2/4 kV / 5 kHz	ČSN EN 61000-4-4
Surge	1,2/50 μs	ČSN EN 61000-4-5
Radiation	0,15 - 30 MHz	ČSN EN 55011

Temperature range

from -25 to +55 °C

Terminals

one conductor from 1,5 to 6 mm²
two conductors from 1 to 2,5 mm²

Weight

2,5 kg

Information required for ordering:

Un - nominal voltage (100/√3 V; 100 V; 230 V; 400 V)

fn - nominal frequency (50; 60 Hz)

E - auxiliary voltage range, (18 - 60 V DC, AC; 40 - 265 V DC, AC)

contacts of output relays (3x make; 3x break)

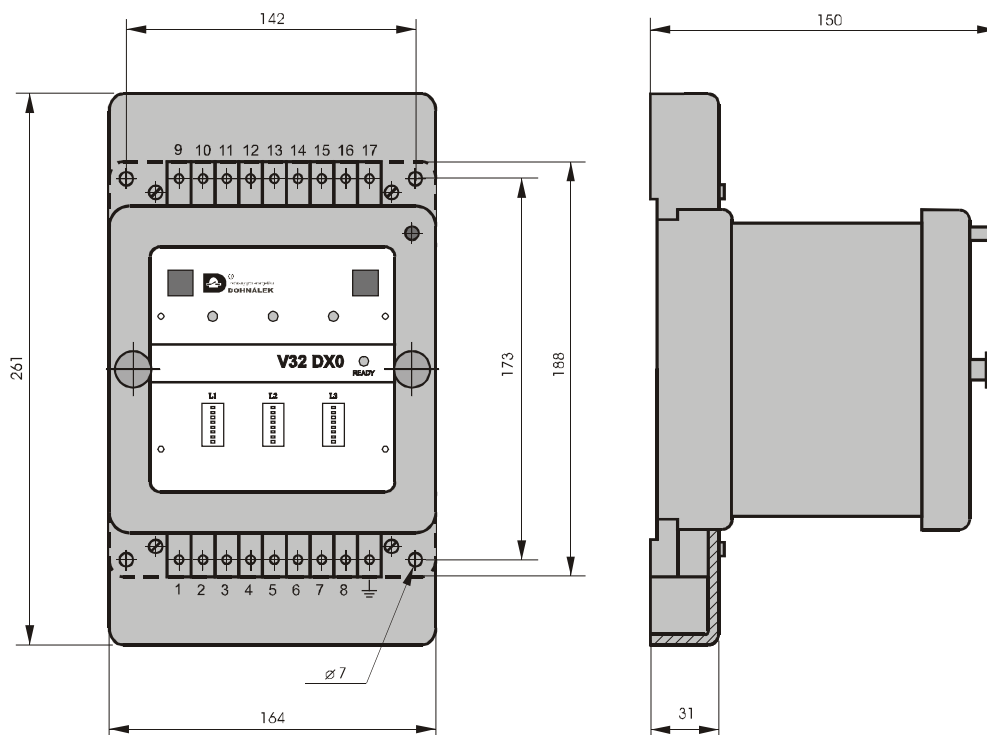

Fig. 3 The terminals position and V 32 DX0 protection dimensions